



Bench for Critters (kids)

(3'l x 1'h x 11'w)



Objective	Time	Difficulty	Age	Participants
Build one child's sized bench for 2-4 kids	1.5 hrs	Medium	12 yrs +	2-4

Tools	Materials
Sanding block 3"w x 4"l x 1" thick 3" Paint brush Japanese hand saw, or western saw Combo square - optional Measuring tape Clamp (1 foot opening width minimum) Pencil Surface to clamp to for cuts Drill, 3/32" drill bit, and screw tips (match tip to screw)	Wood (nominal measurements): 1 pc 1" x 6" w x 10' long or 2 pcs 1" x 6" w x 6' long Wood (nominal measurements): 1 pc 2" x 4" x 8' 1 box of 2" deck screws ½ c linseed oil, ¼ c turpentine, rag, plastic tarp 2 pc sandpaper: (1) 150 grit (1) 220 grit Lumber Cut List: A. (2) pc 1" x 6"w x 36"l [top] B. (2) pc 2" x 4"w x 33.5"l [side braces] C. (4) pc 1" x 6"w x 12"l [legs] D. (2) pc 2" x 4"w x 8"l [end braces]

How To:	** drawings not to scale! **
---------	------------------------------

1. Measure and Cut: All lumber to sizes specified in Cut List (above), triangle cut outs for each leg (C), and joints for legs and braces (B).

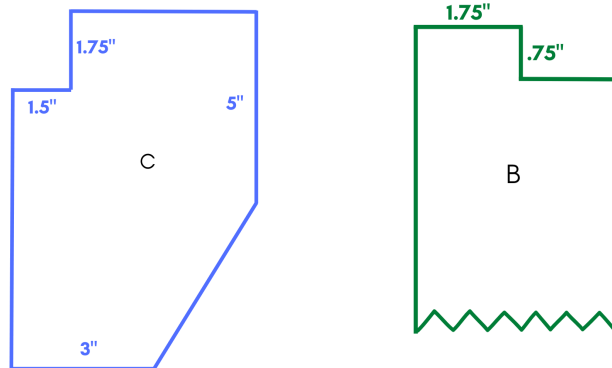

2. Measure, mark, and pre-drill pilot holes to prevent splitting.

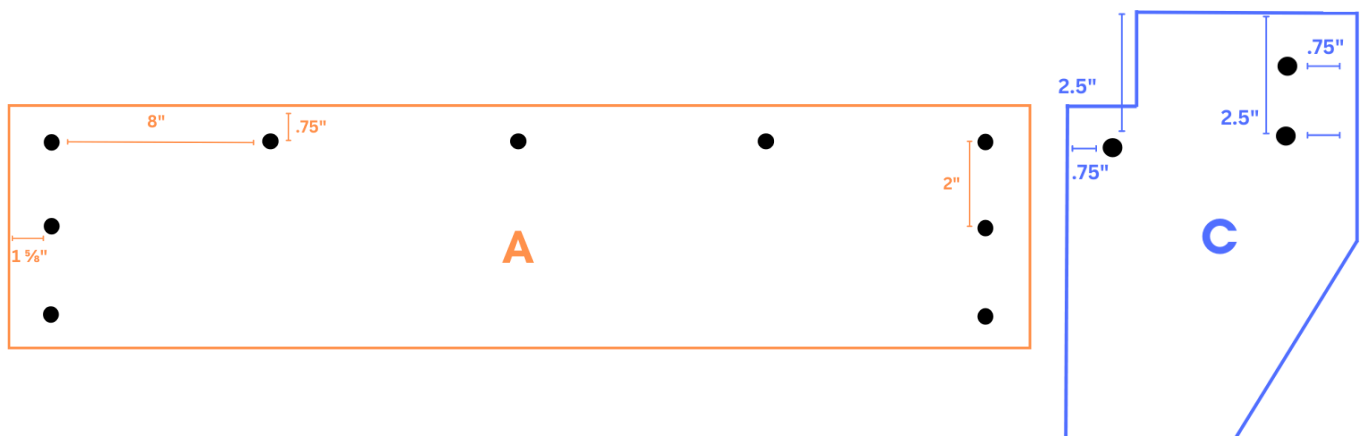

3. Toenail screws where the dotted lines are placed on piece B in order to fasten B and D together, see drawing.

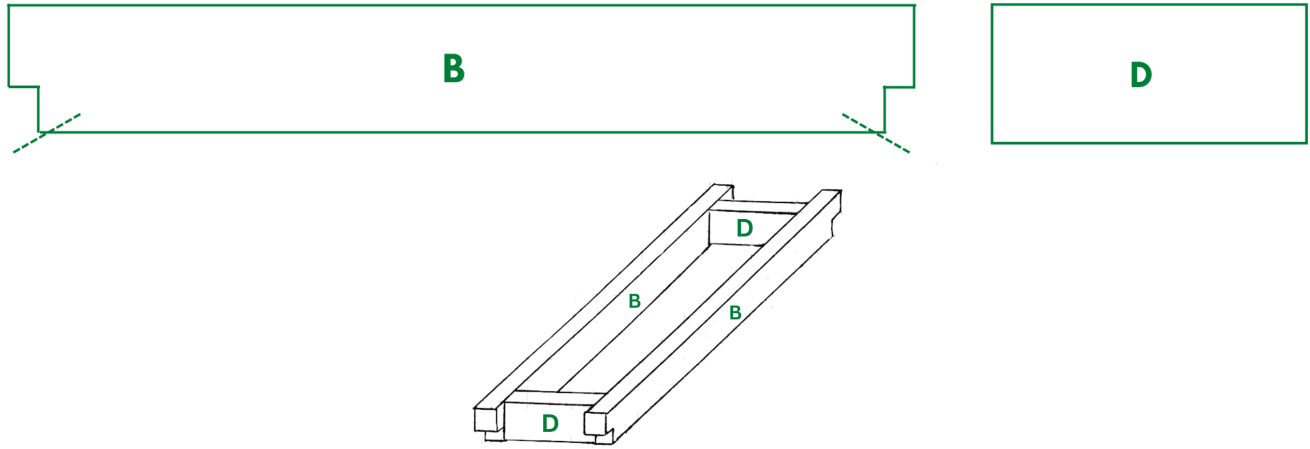

4. Screw legs to brace, then screw top to brace.

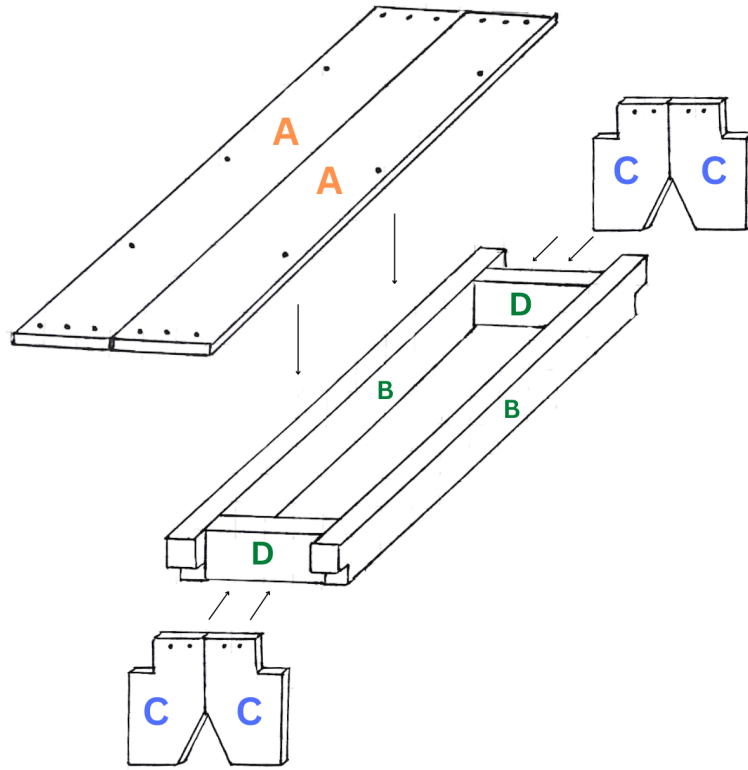

5. Sand bench with 150 grit sandpaper, wipe with damp rag, let dry, and then sand with 220 grit. Wipe down with a damp rag.

6. Mix linseed and turpentine. Place the bench on a tarp and apply the mixture with a brush. Store remaining mixture sealed in a cool place and apply daily until used up.